



TITAN™ Tubular Steel Fencing

TITAN™ tubular steel fencing is a highly robust, yet very stylish security fencing solution, which is extremely versatile making it ideal for a wide range of medium security fencing applications.

5 YEAR WARRANTY*



New Zealand made and galvanised

Our manufacturer designs, manufactures and galvanises TITAN™ tubular steel fencing in New Zealand to guarantee consistently high levels of product quality – typically lacking in other imported alternatives. The robust hot-dipped galvanised steel finish of TITAN™ requires very little ongoing maintenance.

Extremely versatile

TITAN™ tubular steel fence panels offer outstanding versatility. TITAN™ panels are available in a standard dimension of 1900mm (H) x 2370mm (W) and come with either 2 or 3 rail options. Fully welded raked (sloped) panels and a full range of matching gates are also available. Mr Fencer is likely to soon be adding other standard panel sizes. In the interim, we are able to customise orders to any size, to meet your specific requirements.

Simple, stylish and secure

TITAN™ fencing is simple to install and low maintenance making it an extremely easy fencing solution to work with. Its clean, stylish lines make it an ideal option for perimeter fencing, and its inherent anti-climb properties, tamper-proof construction and sliced-point spike top make it seriously secure for the ultimate in peace-of-mind protection for your premises.



Ideal applications

- Security yards
- Schools and sports grounds
- Medical centres
- Medium security installations
- Stock yards
- Storage facilities
- Goods delivery areas
- Warehouses
- Golf courses
- Pools and landscaping

NEPTUNE™ Pool & Landscape Fencing

Utilising TITAN™ fencing technology, NEPTUNE™ tubular steel fencing is now available to specifically meet pool and landscaping needs. Delivering the same inherent product benefits as TITAN, NEPTUNE™ pool and landscape fencing features a safety conscious flat top on each tube. NEPTUNE™ is ideal for environments that require solid, yet stylish fencing, retaining walls and balustrades, and a full range of safety gates are available to match and complete your project.



5 YEAR WARRANTY*



TITAN™ Tubular Steel Fencing - robust, stylish secure

5 YEAR WARRANTY*

Installation and safety

In the interest of safety, TITAN™ tubular steel fencing and NEPTUNE™ pool and landscape fencing should be installed by an experienced installer. Your specialist installer will be able to recommend the best and most cost-effective configuration for your security needs.

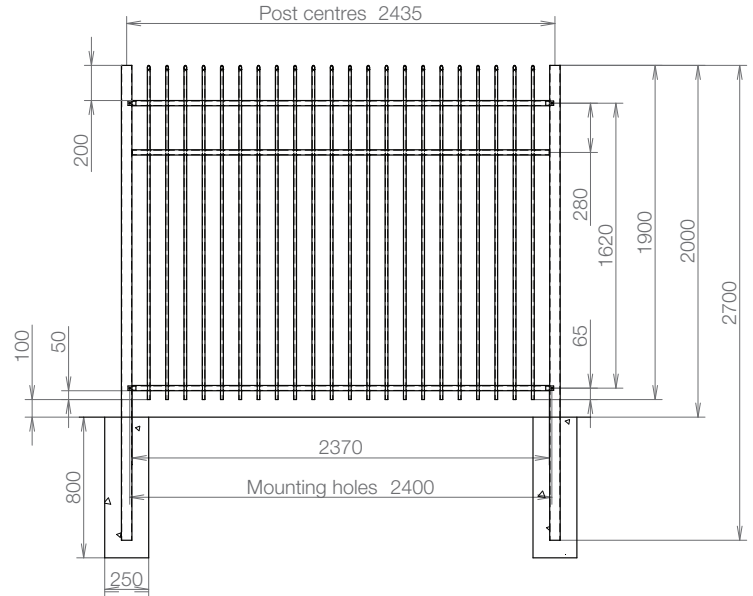
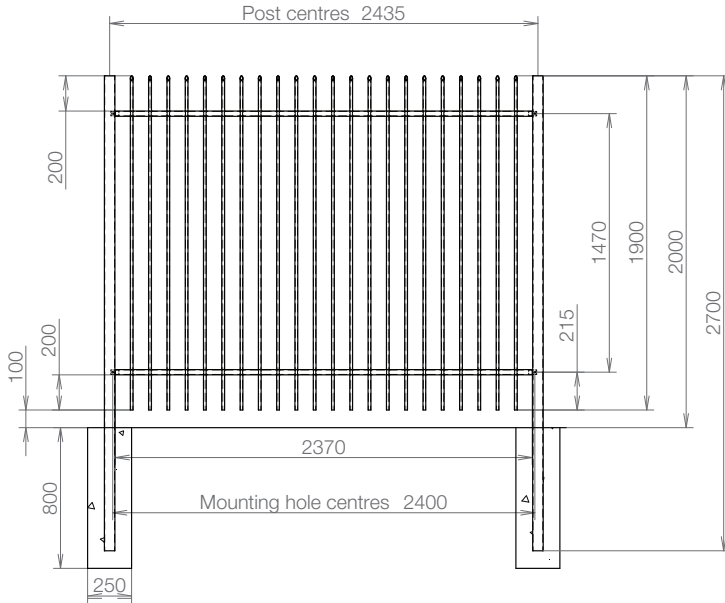

TITAN™ FENCE 2-RAIL

Cross Rail	30 x 40 x 2.0 wall-section
Vertical Tubing	Dia. 16 x 1.6 wall-section
Post	60 x 40 x 2.0 wall-section

TITAN™ FENCE 3-RAIL

Cross Rail	30 x 40 x 2.0 wall-section
Vertical Tubing	Dia. 16 x 1.6 wall-section
Post	60 x 40 x 2.0 wall-section

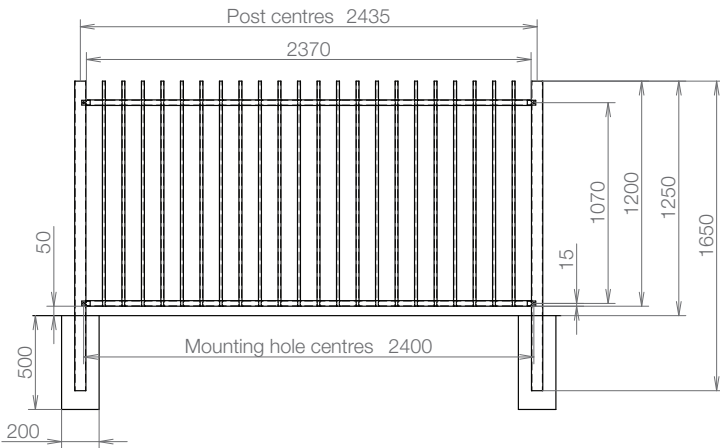

NEPTUNE™ FENCE

Cross Rail	30 x 40 x 2.0 wall-section
Vertical Tubing	Dia. 16 x 1.6 wall-section
Post	60 x 40 x 2.0 wall-section

Specifications

Purpose designed base plates:

Available as unfinished cast aluminium or can be powder coated to any colour you choose. Special dynabolts are used to ensure a flush and discrete finish.



Finishes: Able to be powder coated to any colour you choose - paint and finishes will not be covered by the 5 Year Warranty.

Standard panel sizes: TITAN™: 1900mm (H) x 2370mm (W)
NEPTUNE™: 1200mm (H) x 2370mm (W)

Post and rail sizes: Posts: 60 x 40 x 2.0mm,
Cross rails: 30 x 40 x 2.0mm, Vertical tubing: Dia. 16 x 1.6mm

Optional extras: These optional extras are available by request:
Anti-corrosive alloys – for particularly aggressive environments
Custom gates – can be included with optional automation

***5 Year Warranty:** Please note that the 5 Year Warranty is only applicable to standard hot dip galvanised fencing. Paint and finishes are not covered by the 5 Year Warranty.

For more specifications and information about TITAN™ or NEPTUNE™, please call 0800 MR FENCER (0800 673 362)



www.mrfencer.co.nz
info@mrfencer.co.nz
Scott Foster 027 557 9904
Malcolm Davidson 021 434 401